



MEANT FOR SPACE MANAGEMENT

COMPANY PROFILE



 09818748509

 Sales@Spanglesteel.com

 www.spanglesteelproducts.com

INDUSTRIAL SPACE MANAGEMENT SYSTEMS

ABOUT US



Know Us a Bit

Incepted in the year 1998, Spangle Steel has a vision to provide matchless solution for warehousing and storage needs for a variety of industries and organisations. We put our best step forward in manufacturing, supplying and installing an all-inclusive range of office furniture made in metals and steel, slotted angles & display racks, mezzanine floors, mobile racking system, porta cabins, prefab building systems and much more.

Located in the boisterous city of New Delhi, we have achieved an in-depth knowledge during a decade of broad experience in this industry which leads us to new levels of accomplishment. We are growing remarkably in the domestic markets. We provide outstanding level of satisfaction to our clients by working in tandem with our highly specialized and skilled team of professionals. A perfect amalgam of professionals and highly active R&D wing facilitates us to establish ourselves in this competitive scenario. With the assistance of strategic tie-ups with various reputed C&F agents, we never fail to meet the testing demands of our clients with enthusiasm and within stipulated time. A flawless and innovative range of products with customization is made available together with a competitive pricing policy.

OUR PRODUCT RANGE

A highly customized storage system is made available to our clients for utmost utilization of space with a decent yet stylish look. Our products are manufactured with Anti-Rust materials for a long lasting and resilient life. Our range of offerings includes the following:

1	Slotted Angle Racks	Pallet Racks	Mezzanine Floor
2	Display Racks	Industrial Shed	Two/Three Tire Racks
3	Library Stacks	Porta Cabins	Cable Trays
4	Mobile Racking System	PreFab Building Systems	Pallets

FEATURES

The prominent features that provide our products an edge over others are enlisted below:

- » Robust and stylish design
- » Optimum space / Highly space saving
- » Superior finishing
- » Resistant to corrosion
- » Trouble-free installation
- » Low Maintenance
- » Flexible applications
- » High safety levels

PRODUCTION APPLICATION AREAS

Our range of versatile and durable storage systems are best for :

- » Warehouses
- » Godowns
- » Malls & Retail outlets
- » Factories
- » Libraries
- » Banks and offices
- » Industrial establishments
- » Logistic industry
- » Workshops
- » Record rooms
- » Site offices

OUR QUALITY

Our range of versatile and durable storage systems are best for :

An organisation can please and satisfy clients only by having a hold over superior quality. We here in SPANGLE STEEL PRODUCTS, see to it that stringent quality control programs are operated to match the expectations of clients from different industries. Our quality control experts implement strict scrutiny at each level of production, which starts right from procuring pf raw materials and continues till the shipment of final products. The raw material is procured by us from authenticated vendors of the market. To ensure the zero defect quality of our storage systems, our products undergo strict tests on the basis of following parameters:

- » Dimension
- » Strength and durability
- » Uniform Finishing
- » Sharp edges
- » Coating
- » Load bearing capacity
- » Misalignment



MEZZANINE FLOORS

We are Leading Modular Mezzanine Floor Manufacturers, Exporters, Suppliers in India.

We are the Prominent Manufacturer of Mezzanine Floor, We provide outstanding level of satisfaction to our clients by working in tandem with our highly specialized and skilled team of professionals. A perfect amalgam of professionals and highly active R&D wing facilitates us to establish ourselves in this competitive scenario. With the assistance of strategic tie-ups with various reputed C&F agents, we never fail to meet the testing demands of our clients with enthusiasm and within stipulated time. A flawless and innovative range of products with customization is made available together with a competitive pricing policy.

It's ideal for places where large amount of space generation is required. In industries, warehouses or shops where there is humongous requirement of space for storage and carrying out various processes, they provide the best solution for effective utilization of space. No additional cumbersome construction of bricks is required which drains you of your time and energy.



These Mezzanine floors are made with nuts and bolts hence no cement work, They are very stable and have strong structural integrity. The design and size can be manipulated according to the client's site where it is to be installed.

We have achieved paramount success in manufacturing, trading, wholesaling and supplying of Mezzanine Floor. These trolleys come with a very good capacity and are very easy to handle as well.

MULTI TIER MEZZANINE FLOORS

Modular Mezzanine Floor is a steel platform that is raised from the normal floor level but isn't as high as the ceiling. It is an intermediate floor between the two main consecutive floors of a building and is low-ceilinged. They are a stupendous way of creating extra space in areas where there is a paucity of space and the requirement exceeds the availability. The material rule is the deciding factor for the cost. Floors constructed using structural steel are very heavy but are cheap in pricing. It has the maximum column spacing. They are pleasant in appearance and are best suited for public buildings. Though, they are light but still can bear colossal amount of weight.





FOR SPACE



DOUBLE DECKER MEZZANINE FLOOR

M. S. MEZZANINE FLOOR



RAMP

STAIR

LIFT

The combination of free standing and shelving mezzanines in a total concept creates space, which can guarantee an optimal interaction of goods in and goods out in the storage area. The linking of cranes to storage and/or shelf mezzanines improves the flow goods customer service based on storage concepts.

PERFORATED FLOORING

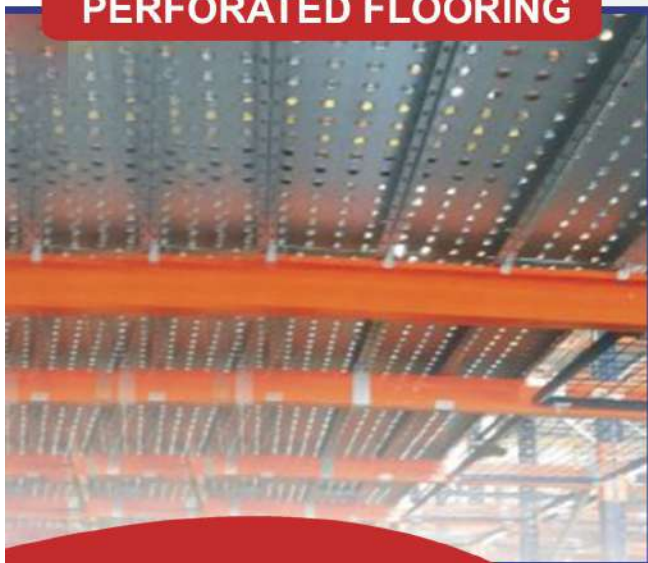

M.S. MEZZANINE FLOOR



HEAVY DUTY PANEL RACKS



HEAVY DUTY PANELS RACKS



we are popularly identified as **Heavy Duty Panel Rack manufacturers**. Being foremost metal storage manufacturers in India

Many industries use racks as their storage device it is because they are flexibility and reliable in nature.

HEAVY DUTY PANELS RACKS



HEAVY DUTY PANELS RACKS



DRIVE IN SYSTEMS

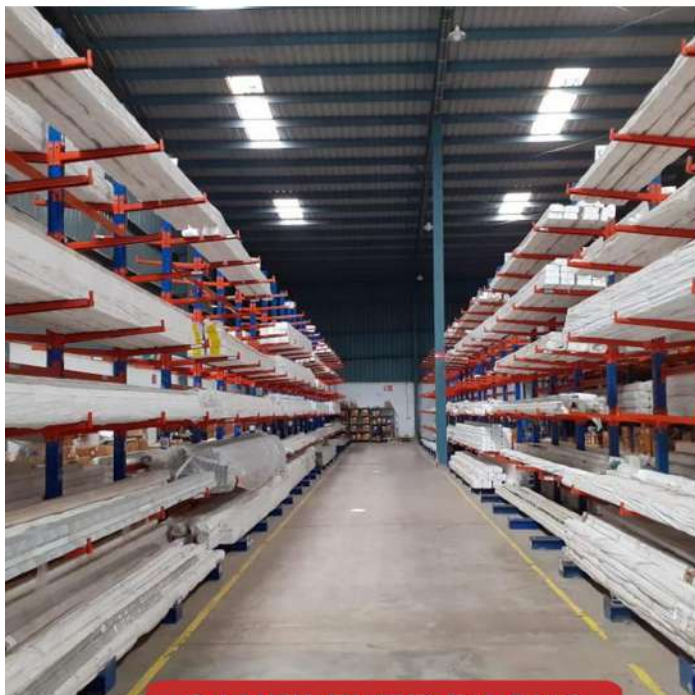

CANTILEVER RACKS

We have achieved paramount success in manufacturing, trading, wholesaling and supplying of **Heavy Duty Racks**. These trolleys come with a very good capacity and are very easy to handle as well.



DIE MOULD RACKS

HEAVY DUTY PALLET RACKS



HEAVY DUTY PALLET RACKS

Our organization specializes in providing a wide range of **Pallet Racks** to our clients at industry leading prices. These racks find wide usage in the warehouses of textile, pharmaceuticals, chemicals, logistics, cement, food, automobile and other industries. These are fabricated using superior quality metal that ensures long service life.



MULTI TIER RACK SYSTEM

HEAVY DUTY PALLET RACKS



HEAVY DUTY PALLET RACKS

FEATURES

- Large & strong components
- Capacity of bearing heavy load
- Wide uprights and deep frames
- Enhanced performance at lower cost

We have achieved paramount success in manufacturing, trading, wholesaling and supplying of **Heavy Duty Pallet Racks**. These trolleys come with a very good capacity and are very easy to handle as well.



Pallet Racks with Panel System

THREE TIER/ MULTI TIER RACKS



We are Leading three tier / multi tier racks Manufacturers, Exporters, Suppliers in India.

We manufacture and supply slotted angle racks of various dimensions and sizes as per the requirement of the client. We offer facility of holes in such a way that panel of any size can be fitted and accordingly load can be managed. these slotted angles are useful in many paces like laboratories, work shops, libraries and officeses.

SEMI / LIGHT DUTY RACKS



We are Leading Semi / Light Duty Racks Manufacturers, Exporters, Suppliers in India.

We manufacture and supply slotted angle racks of various dimensions and sizes as per the requirement of the client. We offer facility of holes in such a way that panel of any size can be fitted and accordingly load can be managed. These slotted angles are useful in many places like laboratories, work shops, libraries and offices.

We have achieved paramount success in manufacturing, trading, wholesaling and supplying of **Semi / Light Duty Racks**. These trolleys come with a very good capacity and are very easy to handle as well.



SLOTTED ANGLE RACKS

We are Leading Slotted Angle Racks Manufacturers, Exporters, Suppliers in India.

We provide outstanding level of satisfaction to our clients by working in tandem with our highly specialized and skilled team of professionals. A perfect amalgam of professionals and highly active R&D wing facilitates us to establish ourselves in this competitive scenario. With the assistance of strategic tie-ups with various reputed C&F agents, we never fail to meet the testing demands of our clients with enthusiasm and within stipulated time. A flawless and innovative range of products with customization is made available together with a competitive pricing policy.



SLOTTED ANGLE RACKING SYSTEM



DISPLAY RACKS

We are Leading Display Rack Manufacturers, Exporters, Suppliers in India.

We provide outstanding level of satisfaction to our clients by working in tandem with our highly specialized and skilled team of professionals. A perfect amalgam of professionals and highly active R&D wing facilitates us to establish ourselves in this competitive scenario. With the assistance of strategic tie-ups with various reputed C&F agents, we never fail to meet the testing demands of our clients with enthusiasm and within stipulated time. A flawless and innovative range of products with customization is made available together with a competitive pricing policy.

Features:-

- Exquisitely designed
- Affordable price
- Meticulous storage purposes



DISPLAY RACKS

We are Leading Display Rack Manufacturers, Exporters, Suppliers in India.

We provide outstanding level of satisfaction to our clients by working in tandem with our highly specialized and skillWe are enlisted amongst the leading names in the industry, offering our clients a wide array of Display Rack that are widely appreciated among the clients for elegant designs and exceptional strength.

Our entire product range is quality tested on varied parameters thereby ensuring its flawlessness. We offer them in different designs and sizes and can be customized as per the preferences of our valuable clients.



PALLETS SYSTEM



PLASTIC PALLET



PLASTIC PALLET



WOODEN PALLET



WIRE MESS PALLET



CAGE BIN



M.S. PALLET

HPT STACKER TROLLEY

THE HPT STACKER TROLLEY is a light weight hand pallet truck with a steering angle of 210 degrees" Weighing only 75 kg, it offers an unmatched weight to capacity ratio" li is designed for easy maneuver ability "particularlyY in confined areas.

Fork Size 1150mmwidth 550mm

Capacity 2500Kgs

Lift Height 205mm

Lowered Height 85mm

Wheel Nylon

Engineering Excellence Easy maintenance : 12 Lubrication grease niPPles on allmovable parts for easy maintenance. Operator comfort: Ergonomic large. handle. with three Dosition control lever & foot operated lowering lever

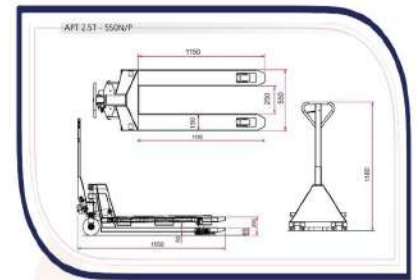
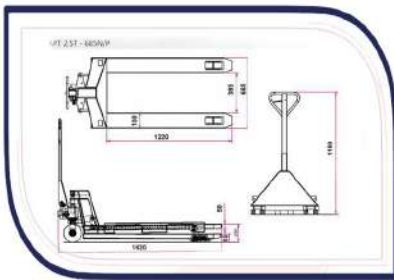

LIFT STACKER

We are Leading Lift Stacker. Manufacturers, Exporters, Suppliers in India.

We provide outstanding level of satisfaction to our clients by working in tandem with our highly specialized and skilled team of professionals. A perfect amalgam of professionals and highly active R&D wing facilitates us to establish ourselves in this competitive scenario. With the assistance of strategic tie-ups with various reputed C&F agents, we never fail to meet the testing demands of our clients with enthusiasm and within stipulated time. A flawless and innovative range of products with customization is made available together with a competitive pricing policy.



WAREHOUSING EQUIPMENT



Hand Palet Trucks



Semi Electric Pallet Racks



Manual Stacker



Semi electric Stacker



Powered Pallet Trucks



Electric Stacker



Electric Reach Stacker



Counter balanced Electric Stacker



Reach Truck



Electric Tow Truck



Articulated Forklift



Aereial Work Platform



Dock Leveler



Boom Lift

MOBILE COMPACTOR

We are Leading Mobile Compactor Manufacturers, Exporters, Suppliers in India.

We provide outstanding level of satisfaction to our clients by working in tandem with our highly specialized and skilled team of professionals. A perfect amalgam of professionals and highly active R&D wing facilitates us to establish ourselves in this competitive scenario. With the assistance of strategic tie-ups with various reputed C&F agents, we never fail to meet the testing demands of our clients with enthusiasm and within stipulated time. A flawless and innovative range of products with customization is made available together with a competitive pricing policy.



MOBILE COMPACTOR

We are Leading Mobile Compactor Manufacturers, Exporters, Suppliers in India.

We hold expertise in manufacturing and supplying a wide range of Mobile Compactor. Manufactured using best quality components these Compactors are extensively recommended for durability and reliability.

- These devices are the perfect blend of robustness, corrosion resistance and high functional efficiency.
- These are extensively acclaimed for high functional efficiency and consistent performance.

Features:-

- Long functional life
- Durability
- Rugged construction



LIBRARY RACKS

We are Leading Library Racks Manufacturers, Exporters, Suppliers in India.

Spangle Steel Products Library Racks are ideal for libraries, educational institutions, schools, colleges, universities etc. It facilitates systematic storage and easy retrieval of books. Library Racks are carefully constructed to utilize the minimum of Space and books stored can be clearly seen and easily accessible. Our Library racks are furnished with many book binds to prevent the books from falling and keep them in standing and beautiful condition.

For a continuous block, one basic section is essential while add-on section can be added to have a block of desired length, The stack can be single faced or double faced, that are operable from one side and from both sides respectively.

We have achieved paramount success in manufacturing, trading, wholesaling and supplying of **Library Racks**. These trolleys come with a very good capacity and are very easy to handle as well.



Library Racks

RACEWAY CABLE TRAY

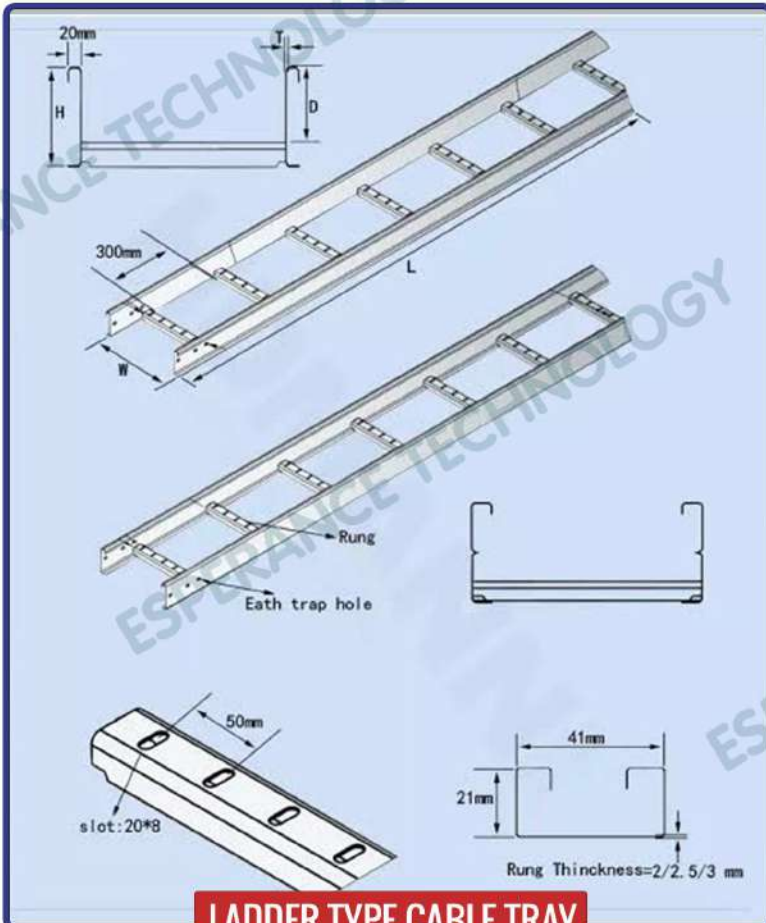
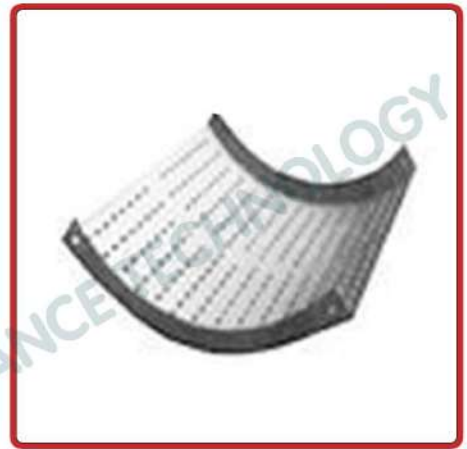
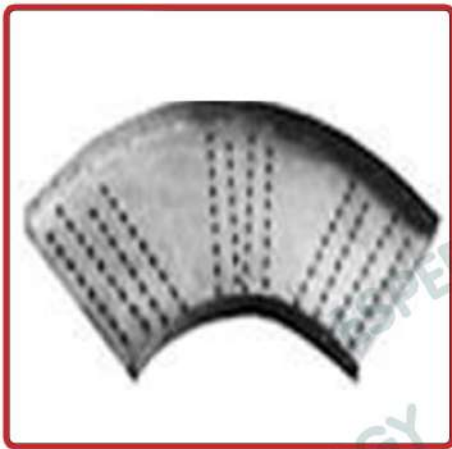
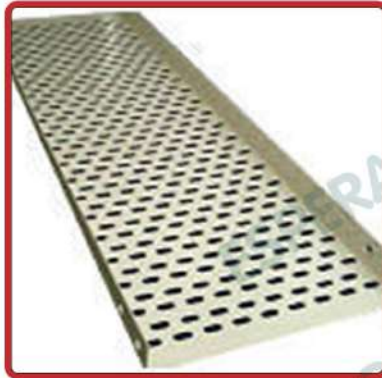

LADDER TYPE CABLE TRAY

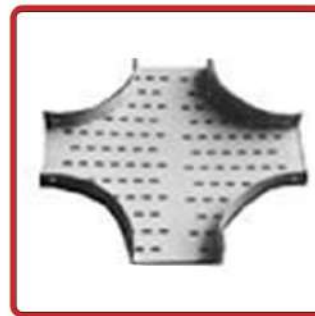

RACEWAY CABLE TRAY



CABLE TRAY

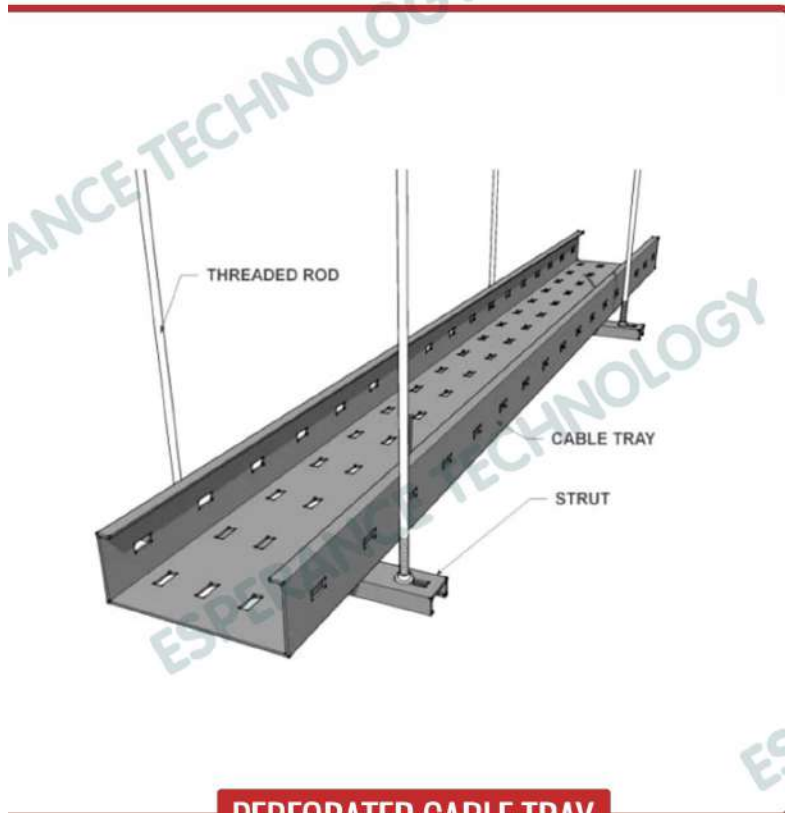

PERFORATED CABLE TRAY



PERFORATED CABLE TRAY

BELT / ROLLAR CONVEYOR SYSTEM

We are Leading Belt Conveyor System Manufacturers, Exporters, Suppliers in India.

Belt Conveyor System is also called Rubber conveyor belt, which is widely used for transporting bulk materials or packed products in mining industry, building materials industry, metallurgy industry, coal and other industries. According to the process requirements, it can achieve single delivery, multiple combinations and the horizontal or inclined conveying system together with other equipment, so as to meet the different operation requirements.

The Belt Conveyors is driven by the motorized pulley and the lifting and running of the whole set is nonmotorized. It is suitable for loading and unloading and to deliver bulk materials or integrated items in short distance. The steel tube structure is light, pleasing and with good mobility.

The transmission device is a motorized pulley equipped with pneumatic tire and steel wheels, and the dip angle can be adjusted if the conveyor length is more than 10m.

Conveyor belt can provide the most reasonable and economic configurations for customers according to their requirements.



INDUSTRIAL SHED



Spangle Roofing Solutions include Spangle AC Roofing and Spangle Hi-Tech, Spangle Roof light and Metal Roofing Spangle Roofing, which is fibre cement corrugated roofing sheets, is being used extensively throughout the country for factories, power plants, stadiums, schools, urban and rural houses, to name a few. Spangle Hi-Tech is a high impact resistance non-asbestos corrugated modern roofing system. Spangle Roof light -another high quality polycarbonate roofing sheet and Spangle Metal roofing.

INDUSTRIAL SHED



Spangle 1060 mm

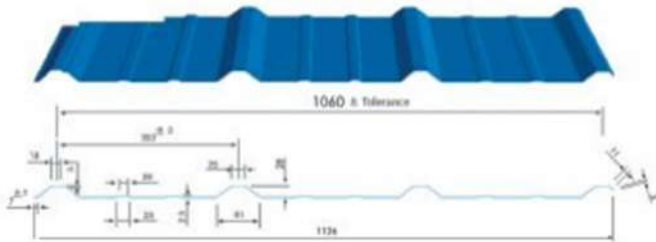

We offer a wide variety of industrial sheds that can be fabricated as per the client's requirement. Our range of industrial sheds is used across various industries in warehouses, manufacturer units and other industrial places and is offered at economical prices.

Its light weightness and panel structural strength is an added advantage for sheds and gets comfortable working atmosphere by reducing the heat inside.



SPANGLE STEEL PRODUCTS



Head Office : A-4/1 (I-1), Upper Ground Floor, Naiwala bagh, Commercial Complex, Usha Kiran Building, Azadpur, Delhi- 110033
Mobile : 09818748509, 09811748509, 09310048509, 07290003841, 9654943059 Tele Fax : 011-27677761
Email : spanglesteel@yahoo.in, spanglesteels09@gmail.com, sales@spanglesteel.com
Website : www.spanglesteel.com, www.spanglesteel.in
Reg. Off. : E-49/A-27, Janta Colony, Road No. 65, Near Raghunath Mandir, Shahdara, Delhi-110053